

# Steering

Special Tools .....	* .....	17-2
System Description		
Steering Column . . .a.....		17-3
Energy-absorbing Steering		
Column /Wheel .....		17-5
Inspection		
Steering Wheel Rotational Play . .		17-6
Steering Effort Check .....		17-6
Power Assist With Car Parked . . .		17-6
Steering Gearbox Adjustment . . .		17-7
Steering Wheel		
* Removal .....		17-8
Disassembly/Inspection .....		17-9
* Installation .....		17-10
Steering Column		
* Removal .....		17-12
Inspection .....	* .....	17-14
* Installation .....		17-15
<b>Manual Steering</b>		
Component Location		
Index .....		17-18
Steering Gearbox		
Removal/Installation .....		17-19
Illustrated Index .....		17-21
Disassembly .....	* .....	17-22
Reassembly . . . * .....		17-25
Ball Joint Boot Replacement .....		17-30

<b>Power Steering</b>	
System Description .....	17-31
Electrical Power Steering .....	17-31
Major Components .....	17-32
System Operation .....	17-33
Function and Operation .....	17-34
Circuit Diagram .....	17-40
Wiring Locations .....	17-41
Troubleshooting	
Troubleshooting Precautions .....	17-42
Troubleshooting Procedures .....	17-43
Test Harness Installation .....	17-45
Troubleshooting	
Steering is heavy .....	17-46
Steering pulls to either side ...	17-47
Indicator light does not	
come on .....	17-47
Indicator light stays on .....	17-49
Troubleshooting chart .....	17-51
Troubleshooting by problem	
code .....	17-52
Component Location	
Index .....	17-63
EPS Gear Box Installation	
and Removal .....	17-64
Illustrated Index .....	17-68
EPS Gear Box Inspection .....	17-69
Ball Joint Boot Replacement .....	17-72
*Power Unit Installation	
and Removal .....	17-73
*EPS Control Unit Installation	
and Removal .....	17-74



## SUPPLEMENTAL RESTRAINT SYSTEM (SRS)

The NSX includes a driver's side Airbag, located in the steering wheel hub, as part of a Supplemental Restraint System (SRS). Information necessary to safely service the SRS is included in this Service Manual. Items marked \* in each section include, or are located near, SRS components. Servicing, disassembling or replacing these items will require special cautions and tools and should therefore be done by an authorized Acura dealer.

### ▲ WARNING

- To avoid rendering the SRS inoperative, which can lead to personal injury or death in the event of a severe frontal collision, all maintenance must be performed by an authorized Acura dealer.
- Improper maintenance, including incorrect removal and installation of the SRS, can lead to personal injury caused by unintentional activation of the Airbag.
- All SRS selectrical wiring harnesses are covered with yellow outer insulation and related components are located in the steering column, center console, dash, and dashboard lower panel. Do not use electrical test equipment on these circuits.

# Special Tools

Ref. No.	Tool Number	Description	Q'ty	Page Reference
①	07GAF-SD40700	Hub Dis/Assembly Base	2	17-24
②	07MAA-SL001 0A	40 mm, Locknut Wrench	1	17-7, 70
③	07MAA-SL0020A	43 mm, Locknut Wrench	1	17-7, 28
④	07MAA-SL0030A	50 mm, Locknut Wrench	1	17-23, 27
⑤	07MA/07M07MAZ-SL00100	Ball Joint Harness Screw Boot Wrench A Clip Guide	1	17-23, 17-30, 17-45, 26, 48, 72, 75, 5
⑥				53, 54, 55, 56,
⑦				59, 60, 61
⑧	07MAZ-SL00200	Test Harness B	1	17-45, 53, 55
⑨	07MAZ-SL00300	Test Harness C	1	17-45
⑩	07MAZ-SL00400	EPS power unit checker	1	17-45, 58
⑪	07941-6920003	Ball Joint Remover	1	17-19, 64
⑫	07973-6920001	P/S Adjustment Guide	1	17-25
⑬	07974-SD90000	Steering Inspection Arm	1	17-22, 26, 69

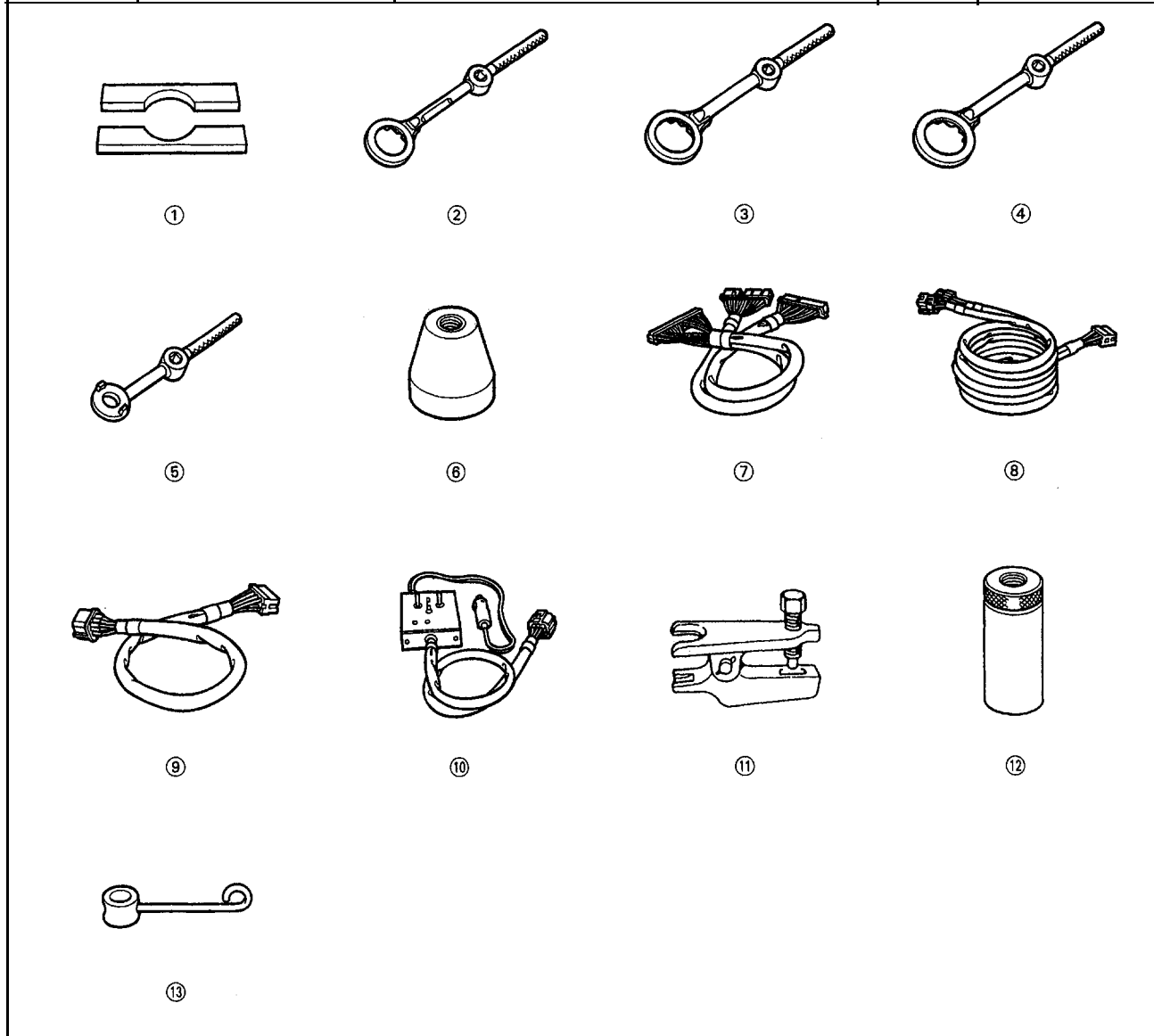



# System Description

## -Steering Column

The NSX has a tilt/telescopic steering column. The tilt/telescopic mechanism makes it possible to adjust the steering wheel in fore and aft, and up and down directions.

### Tilt Mechanism

There is a joint on the upper steering shaft, and the portion of the column between the steering wheel and this joint is adjustable up and down. When the tilt lever is operated, the lock gears are detached from the column gear to release the lock. The column moves upward or downward on two pivot bolts. When the tilt lever is returned to a fixed position after selecting the steering wheel height, the lock gear is engaged with the column gear to secure the column.

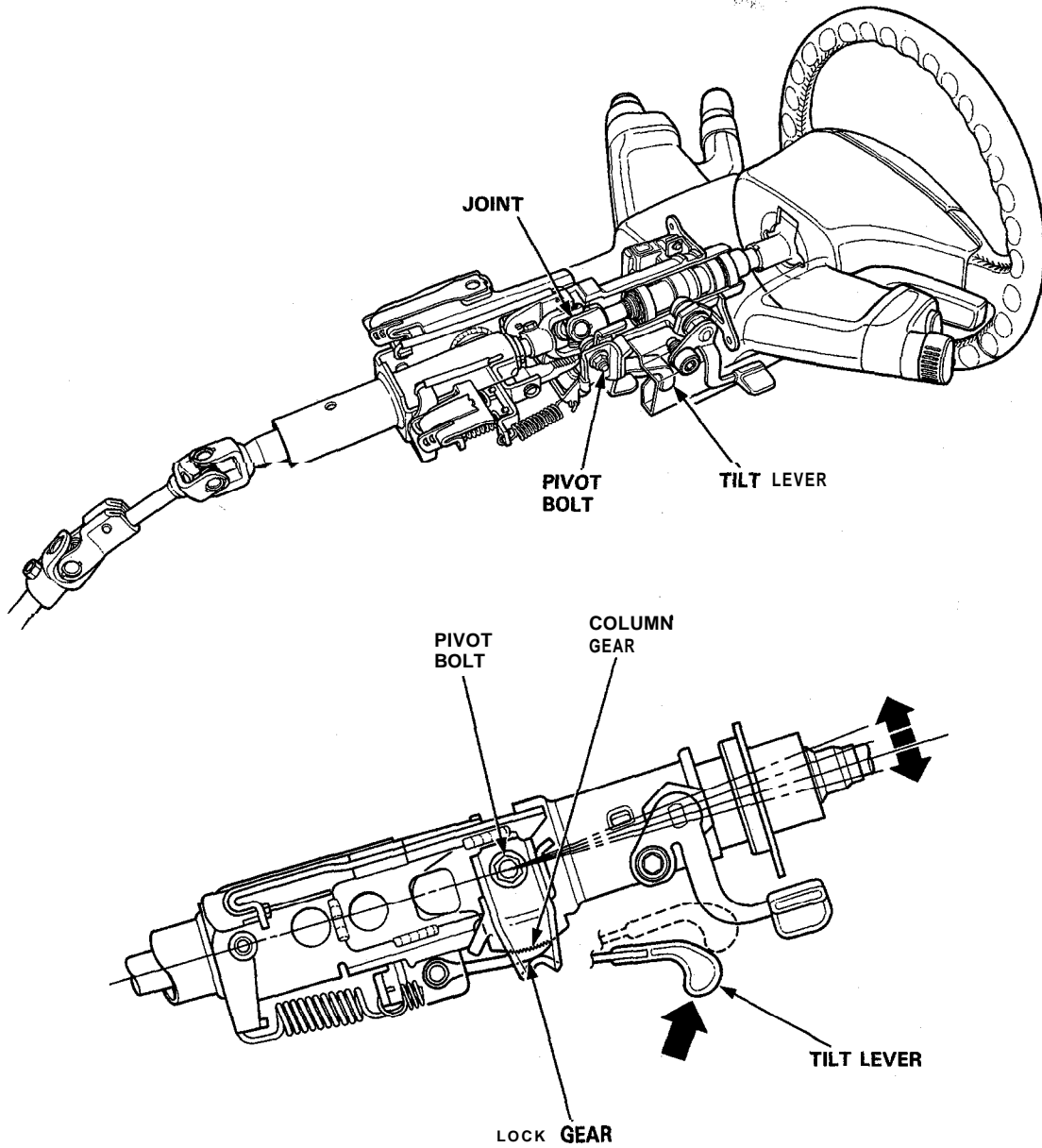

(cont'd)

# System Description

## -Steering Column (cont'd)

### Telescopic Mechanism

The upper steering shaft is divided into two shafts, connected by splines, making it possible for the shaft to telescope while transmitting the rotation of the steering wheel. When the telescopic lever is lowered, the lever pivot turns in a direction to loosen the stopper shim at the tip of the lever pivot, allowing the shaft to make telescope. The telescopic stroke is limited by the slot and stopper on the movable shaft. After selecting a steering wheel position and returning the telescopic lever to the fastening position, the stopper shim is pressed against the movable shaft the lever pivot to fasten the sliding part.

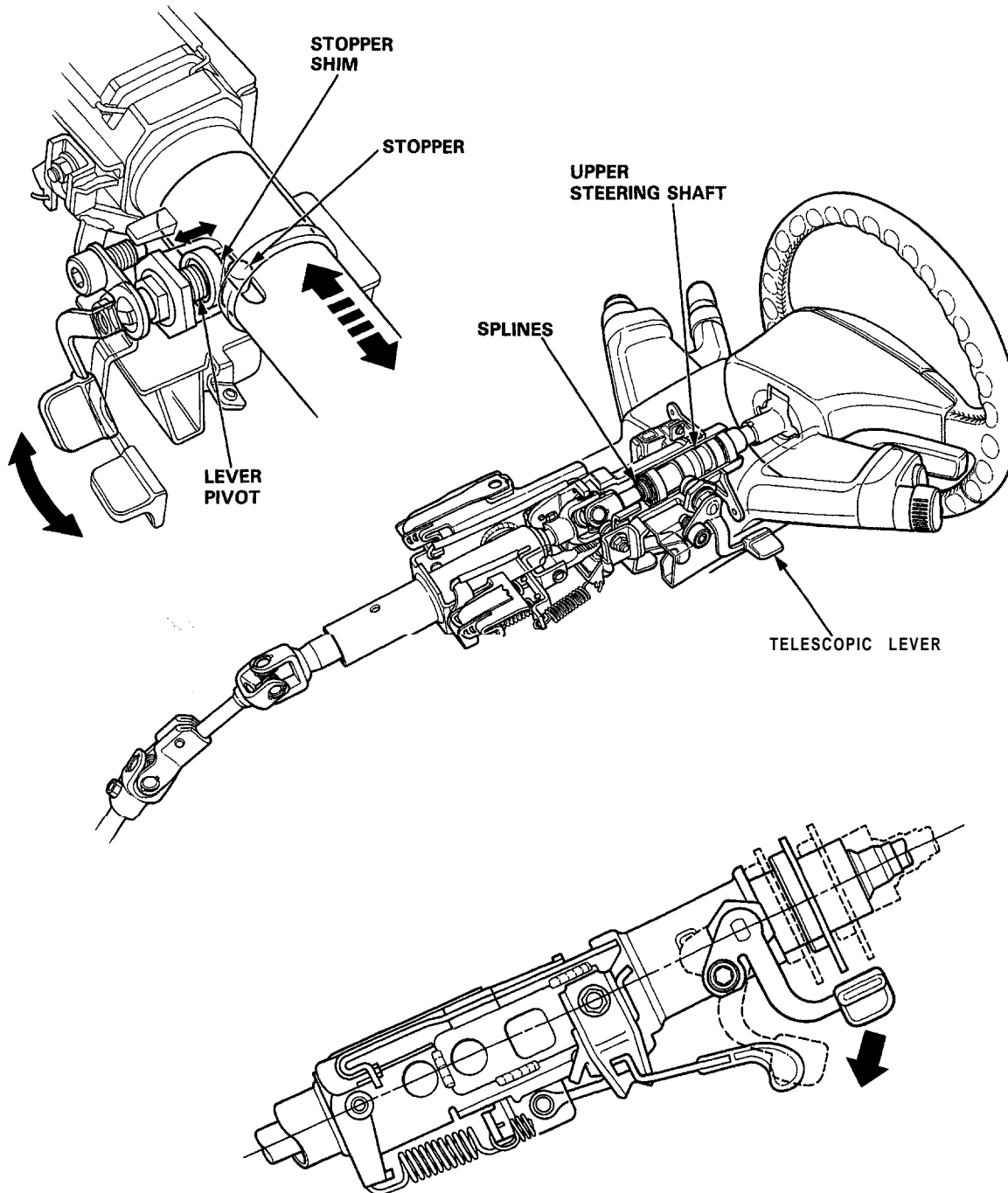



# Energy-absorbing Steering Column/Wheel

Both the steering column and steering wheel are designed to absorb impact energy during a collision.

### Steering Wheel

The steering wheel absorbs the energy of a collision through the deformation of the spoke portion. Should the impact absorbing capacity of the column side decrease due to the deformation of the vehicle body during a collision, the steering wheel will help absorb the impact.

### Steering Column

The steering column is fastened on the body through a U-shaped plate, and the lower part of the column is inserted into a lower holder. Due to this construction, the steering column will slide in its axial direction when a large impact is given in the axial direction of the column. Since the U-shaped plate is fastened to the body, the U-shaped plate is bent and deformed along the guide when the column slides in its axial direction. Through the deformation of the plate, the energy is absorbed and the column slides forward. When exposed to a greater impact, a shear pin will break and the energy is absorbed by the lower shaft.

< UNDER NORMAL CONDITION >

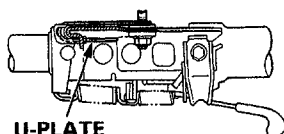

U-PLATE

U-PLATE GUIDE < AT TIME OF IMPACT >

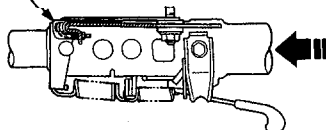

The U-plates absorb an energy while they are straightened by the upper bracket.

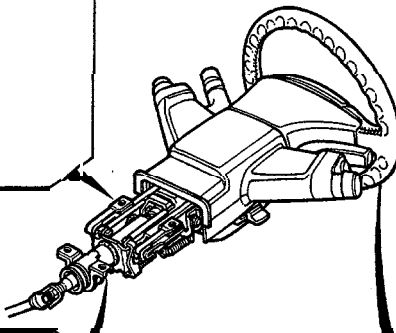

< UNDER NORMAL CONDITION >

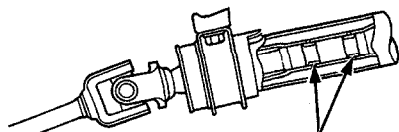

SHEAR PINS

< AT TIME OF IMPACT >

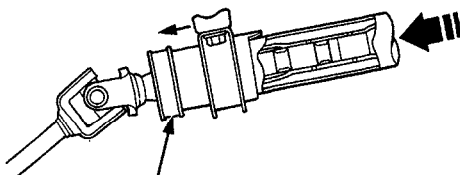

STEERING JOINT

< UNDER NORMAL CONDITION >

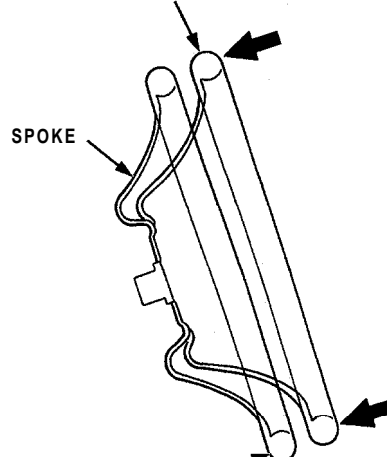

SPOKE

< AT TIME OF IMPACT >

# Inspection

## - Steering Wheel Rotational Play

1. Place the front wheels in a straight ahead position and measure the distance the steering wheel can be turned without moving the front wheels.
2. If the play exceeds the service limit, check all steering components.  
Service Limit: 5 cm (0.2 in)

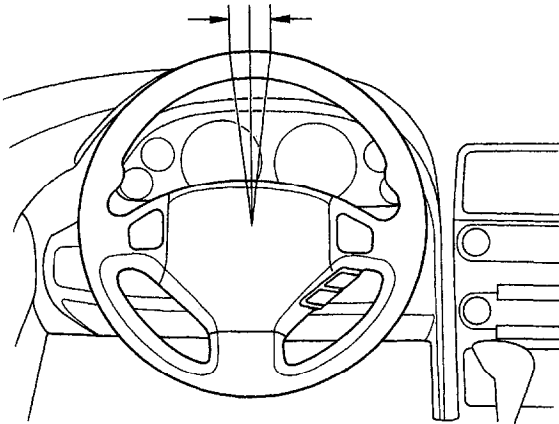

## - Steering Effort Check (Manual Steering Only)

1. Raise the front wheels off the ground (see section 1).
2. Turn the steering wheel with a spring scale and check its reading.
3. If the reading exceeds the service limit, adjust the steering gearbox as shown on the next page.  
Service Limit: 20 N (2 kg, 4.4 lb)

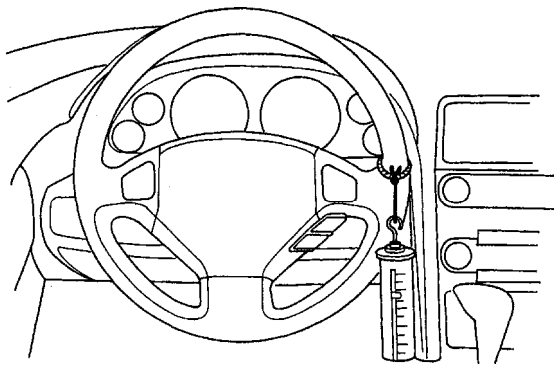

## -Power Assist Check With Car Parked (Electrical Power Steering Only)

Turn the steering wheel with a spring scale. Read the measurement when the front wheels or steering wheel start to move.

Operation Standard

Condition	Stationary Swing operation load
Without power assist (engine off)	12 kg (26.46 lb) maximum
With power assist (engine running)	4.2 kg (9.26 lb) maximum

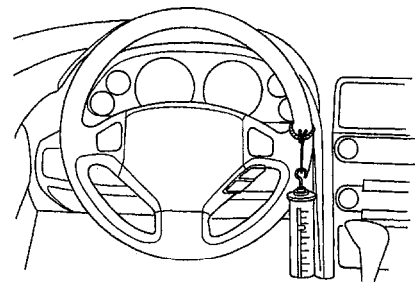



## --Steering Gearbox Adjustment

### Manual Steering:

1. Loosen the rack guide screw locknut.
2. Tighten, loosen and retighten the rack guide screw two times to  $5 \text{ N}\cdot\text{m}$  ( $0.5 \text{ kg}\cdot\text{m}$ ,  $3.6 \text{ lb}\cdot\text{ft}$ ), then back it off  $15^\circ$ .

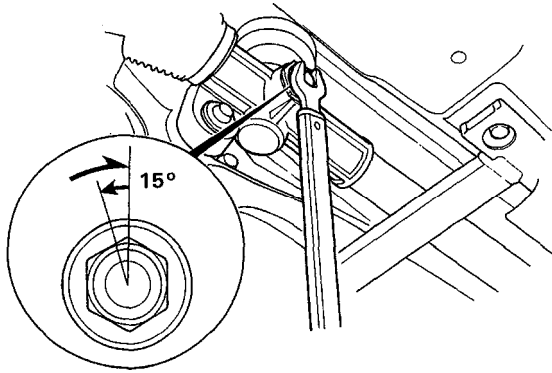

3. Tighten the locknut on the rack guide screw with the special tool.
4. Check for tight or loose steering through the complete turning travel.
5. Recheck steering effort.

To calculate the indicated torque value, use the formula on page 17-26.

Actual:  $66 \text{ N}\cdot\text{m}$  ( $6.8 \text{ kg}\cdot\text{m}$ ,  $49 \text{ lb}\cdot\text{ft}$ )

Indicated:  $52 \text{ N}\cdot\text{m}$  ( $5.2 \text{ kg}\cdot\text{m}$ ,  $38 \text{ lb}\cdot\text{ft}$ )

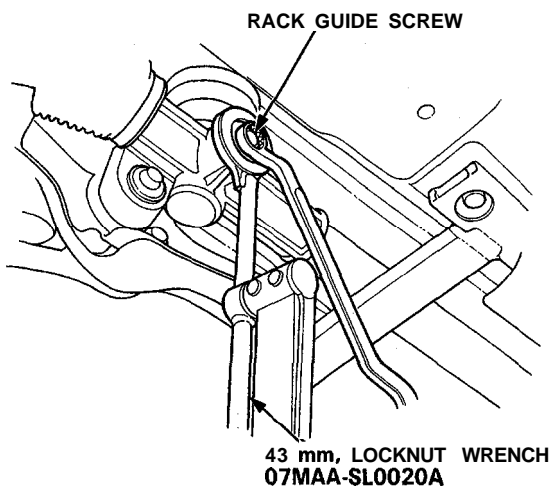

### Electrical Power Steering:

1. Loosen the rack guide screw locknut.
2. Tighten, loosen and retighten the rack guide screw two times to  $4 \text{ N}\cdot\text{m}$  ( $0.4 \text{ kg}\cdot\text{m}$ ,  $2.9 \text{ lb}\cdot\text{ft}$ ), then back it off  $20^\circ \begin{smallmatrix} +5^\circ \\ 0 \end{smallmatrix}$ .

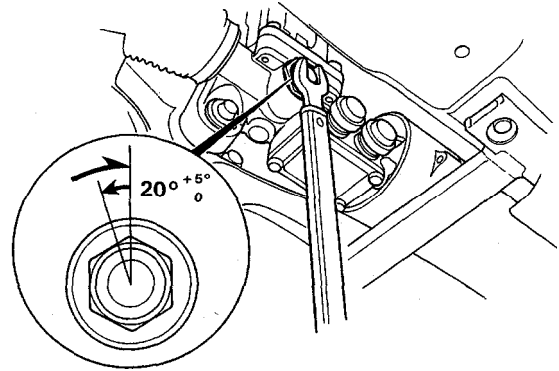

3. Tighten the locknut on the rack guide screw with the special tool.
4. Check for tight or loose steering through the complete turning travel.
5. Recheck steering assist.

To calculate the indicated torque value, use the formula on page 17-70.

Actual:  $25 \text{ N}\cdot\text{m}$  ( $2.5 \text{ kg}\cdot\text{m}$ ,  $18 \text{ lb}\cdot\text{ft}$ )

Indicated:  $19 \text{ N}\cdot\text{m}$  ( $1.9 \text{ kg}\cdot\text{m}$ ,  $14 \text{ lb}\cdot\text{ft}$ )

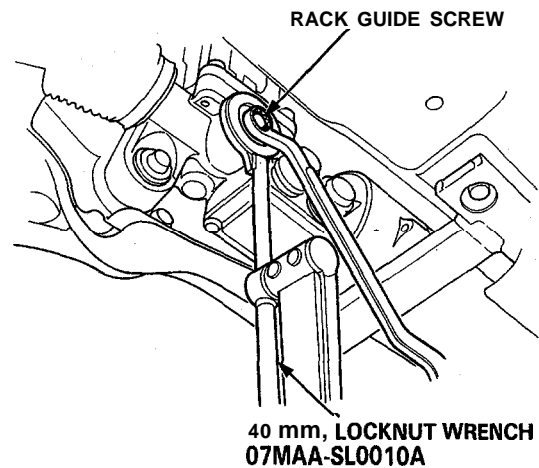

# Steering Wheel

## -Removal

### Airbag Removal

**▲ WARNING** Store a removed airbag assembly with the pad surface up, if the airbag is improperly stored face down, accidental deployment could propel the unit with enough force to cause serious injury.

#### CAUTION:

- Before removing the steering wheel, align the front wheels straight ahead.
- Do not install used SRS parts from another car. When repairing, use only new SRS parts.
- Carefully inspect the airbag assembly before installing. Do not install an airbag assembly that shows signs of being dropped or improperly handled, such as dents, cracks or deformation.
- Always keep the short connector on the airbag connector when the harness is disconnected.
- Do not disassemble or tamper with the airbag assembly.

1. Disconnect both the negative cable and positive cable from the battery.
2. Remove the maintenance lid from the steering wheel lower cover, then remove the short connector.
3. Disconnect the connector between the airbag and cable reel.
4. Connect the short connector to the airbag side of the connector.

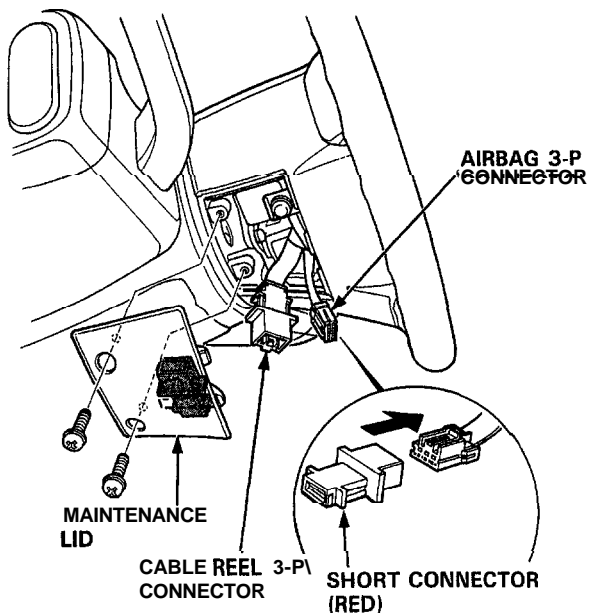

5. Remove the two TORX® bolts using a TORX® T30 bit, then remove the airbag assembly.

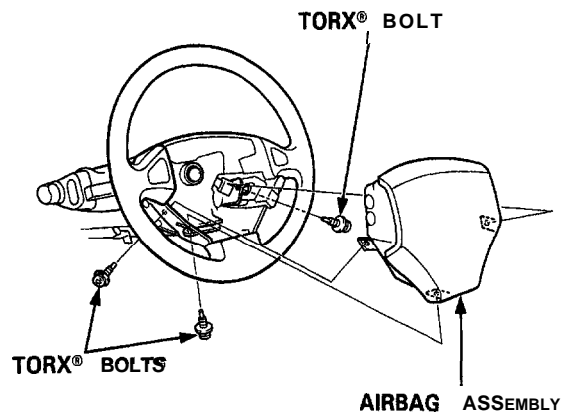
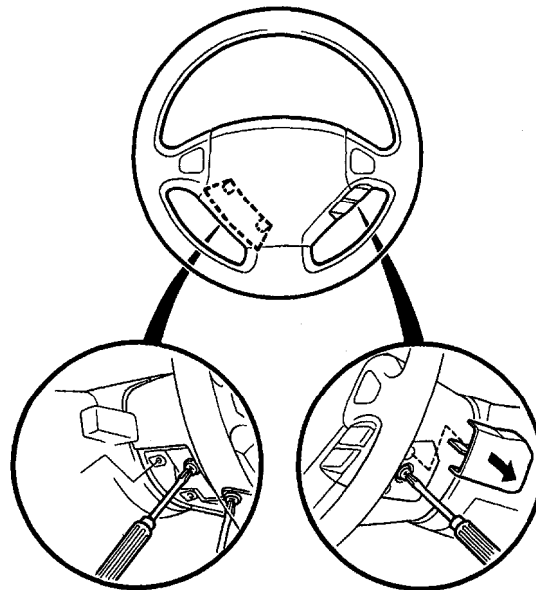

(cont'd)





## -Removal (cont'd)

7. Disconnect the connectors from the horn and cruise control set/resume switches remove the airbag connector from its dips.

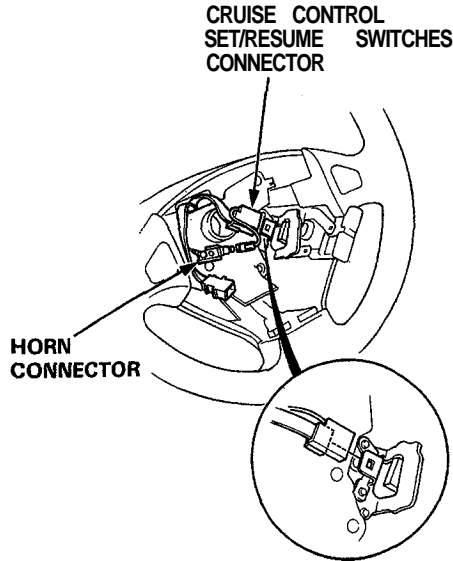

8. Remove the steering wheel nut.
9. Remove the steering wheel by rocking it slightly from side-to-side as you pull steadily with both hands.

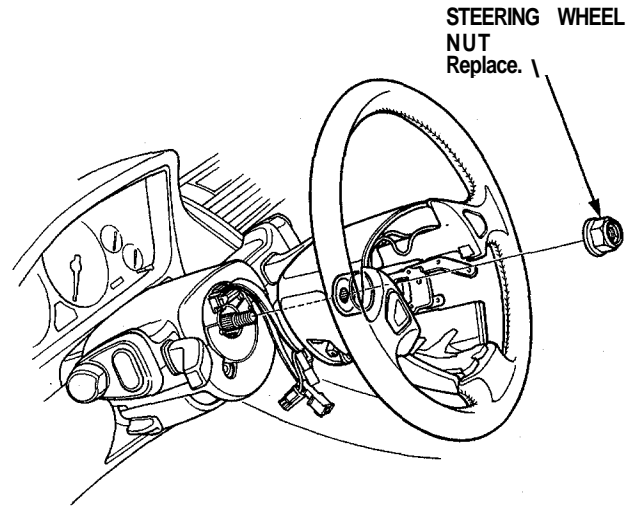

## -Disassembly/Reassembly

**⚠ WARNING** Store a removed airbag assembly with the pad surface up. If the airbag is improperly stored face down, accidental deployment could propel the unit with enough force to cause serious injury.

**NOTE:** If an intact airbag assembly has been removed from a scrapped car or has been found defective or damaged during transit, storage or service, it should be deployed (See section 23).

### CAUTION:

- Carefully inspect the **airbag** assembly before installing. Do not install an **airbag** assembly that shows signs of being dropped or improperly handled, such as dents, cracks or deformation.
- Always keep the short connector on the airbag connector when the harness is disconnected.
- Do not disassemble or tamper with the airbag assembly.

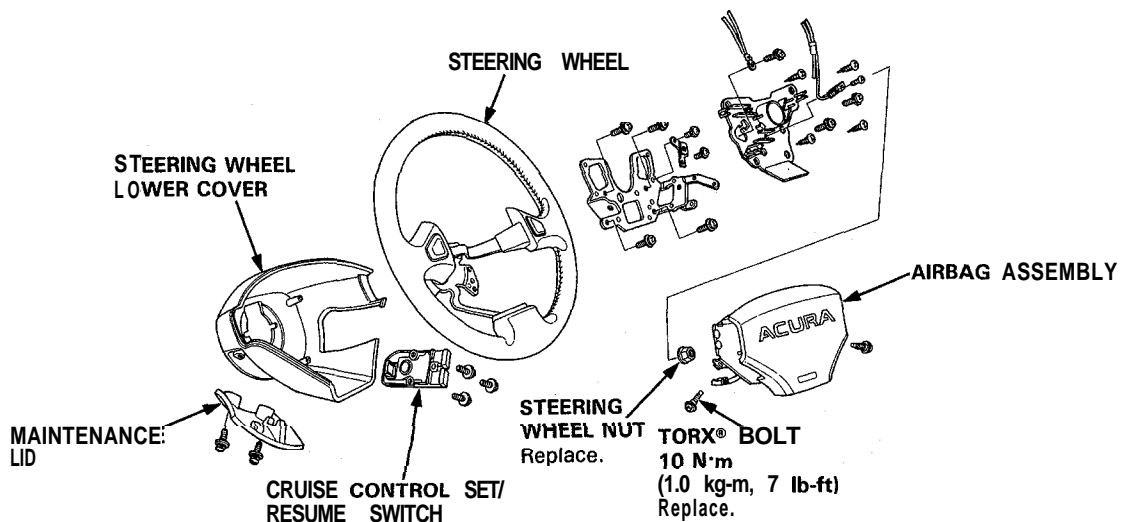

# Steering Wheel

## Installation

### CAUTION:

- Before installing the steering wheel, align the front wheels straight ahead.
- Be sure to install the harness wires so that they are not pinched or interfering with other car parts.
- Do not replace the original steering wheel with any other design, since it will make it impossible to properly install the airbag. (only use genuine HONDA replacement parts)
- After reassembly, confirm that the wheels are still straight ahead and that steering wheel spoke angle is correct. If minor spoke angle adjustment is necessary, do so only by adjustment of the tie rods, not by removing and repositioning the steering wheel.

**▲WARNING** Confirm that the airbag assembly is securely attached to the steering wheel; otherwise, severe personal injury could result during later airbag deployment.

1. Before installing the steering wheel, center the cable reel.  
Do this by first rotating the cable reel clockwise until it stops.  
Then rotate it counterclockwise (approximately two turns) until:
  - The yellow gear tooth lines up with the mark on the cover.
  - The arrow on the cable reel label points straight up.

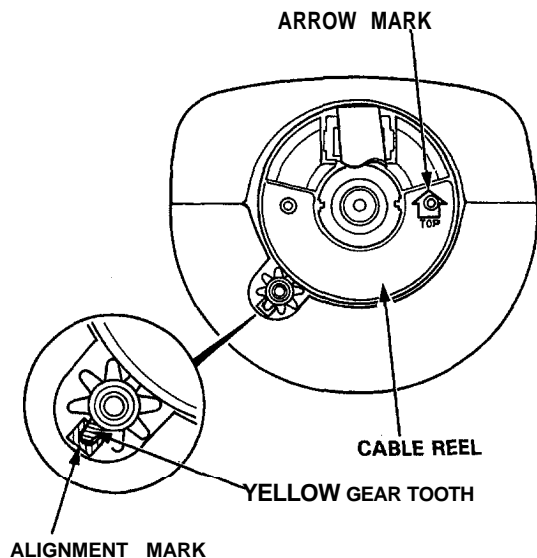

2. Install the steering wheel.  
NOTE: Be sure the steering wheel shaft engages the cable reel.

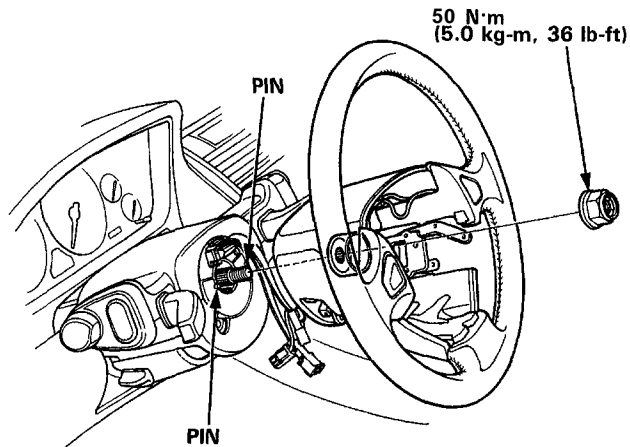

3. Insert the cruise control set/resume 4-P connector and airbag connector to the steering wheel clips.
4. Connect the horn connector.

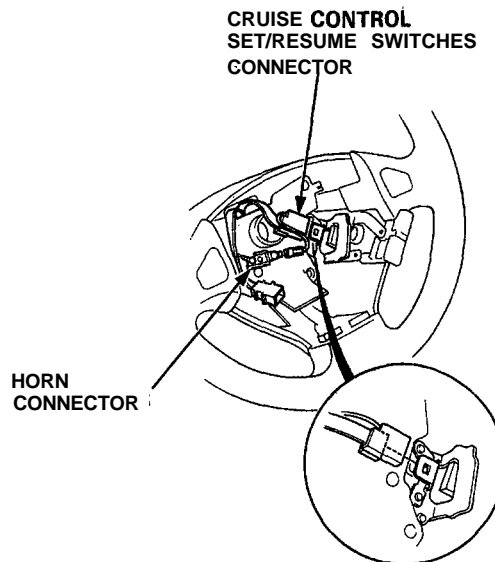



5. Install the airbag assembly with new TORX® bolts.

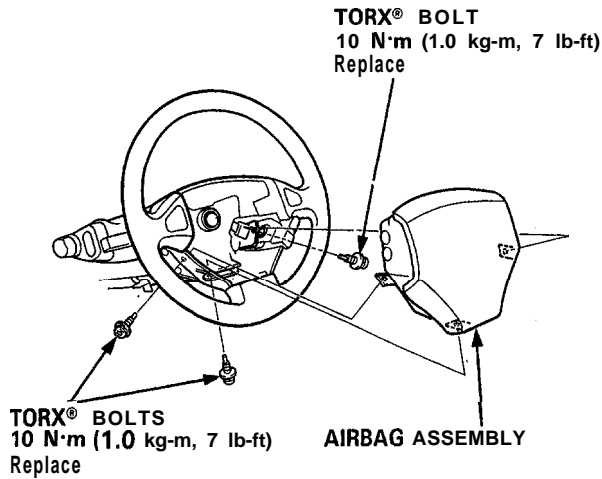

7. Disconnect the short connector from the airbag connector.
8. Connect the airbag 3-P connector and cable reel 3-P connector.
9. Attach the short connector to the lid, and install the lid on the steering wheel lower cover.

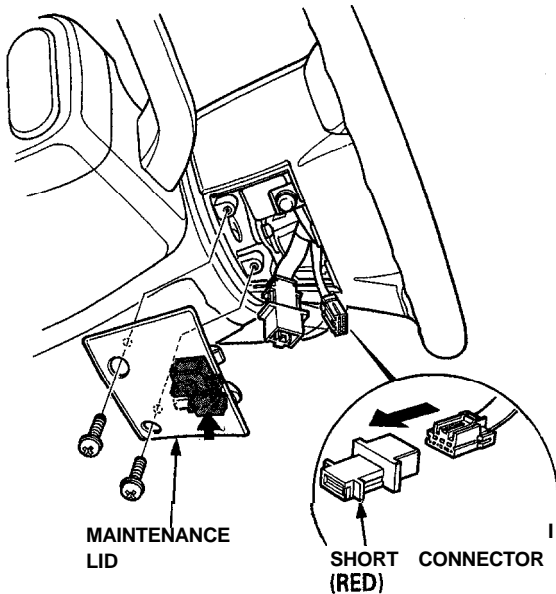

10. Connect the battery positive terminal and then connect the negative terminal.

11. After installing the airbag assembly, confirm proper system operation:

- Turn the ignition to II: the instrument panel SRS warning light should come on for about 6 seconds and then go off.
- Confirm operation of horn buttons.
- Confirm operation of cruise control set/resume switch.
- Turn the steering wheel counterclockwise and make sure the yellow gear tooth still lines up with the alignment mark.

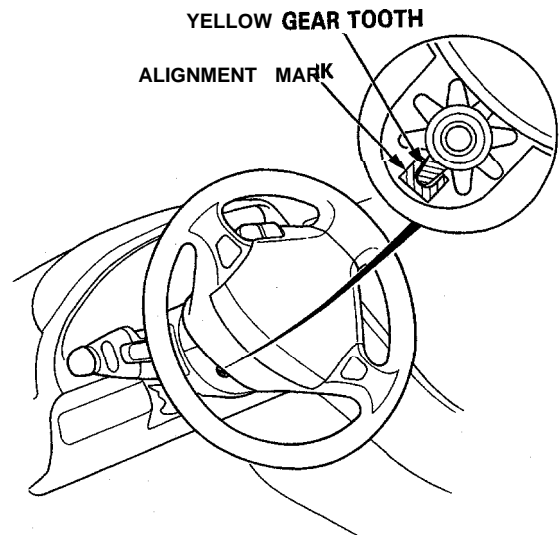

# Steering Column

## -Removal-

1. Disconnect both the negative cable and positive cable from the battery.
2. Remove the airbag assembly and steering wheel from the column (page 17-8).
3. Remove the dashboard lower panel, knee bolster pad, and knee bolster.

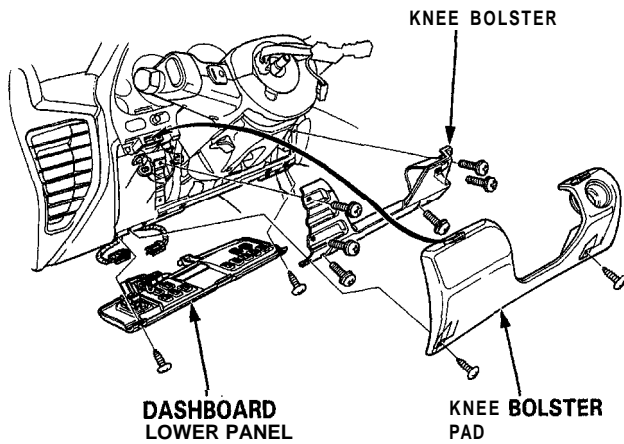

4. Remove the column lower face. Disconnect the connector between the cable reel and the SRS main harness, then remove the connector holder.

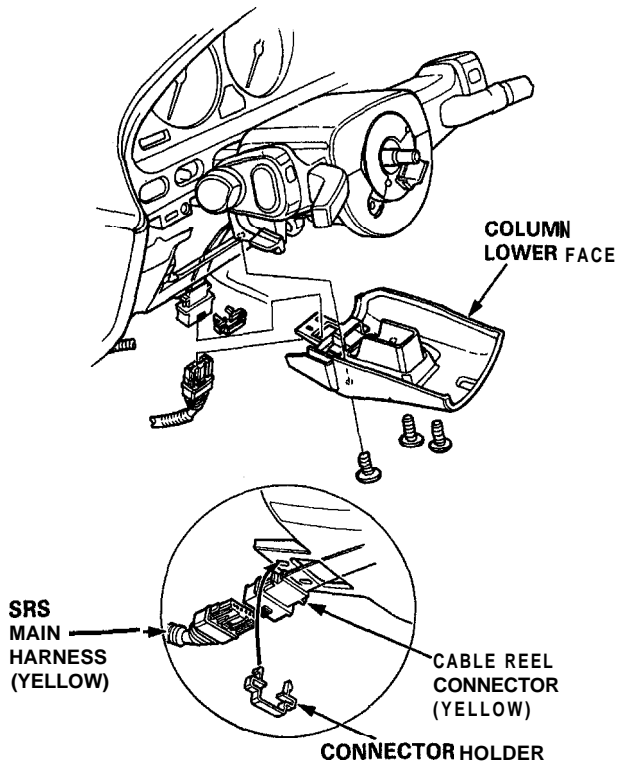

5. Remove the column lower cover, and column upper cover.  
**NOTE:** Be careful not to damage the column covers.

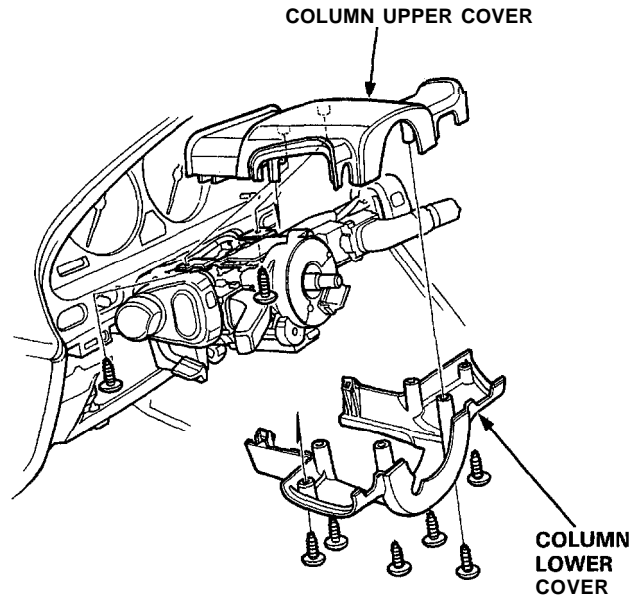

6. Disconnect the TCS sensor.

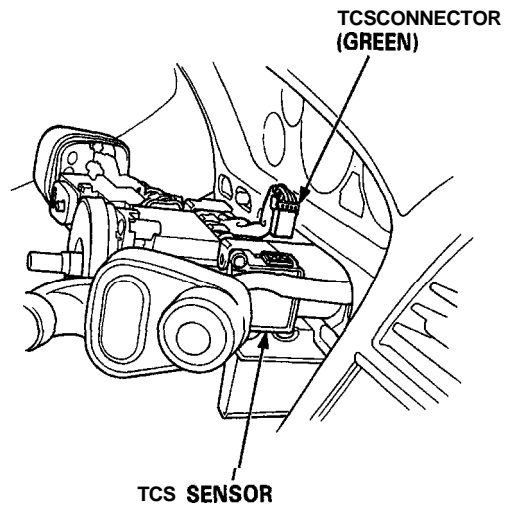



7. Remove the combination switch assembly from the column shaft.

NOTE: The combination switch can be removed by disconnecting only the TCS connector.

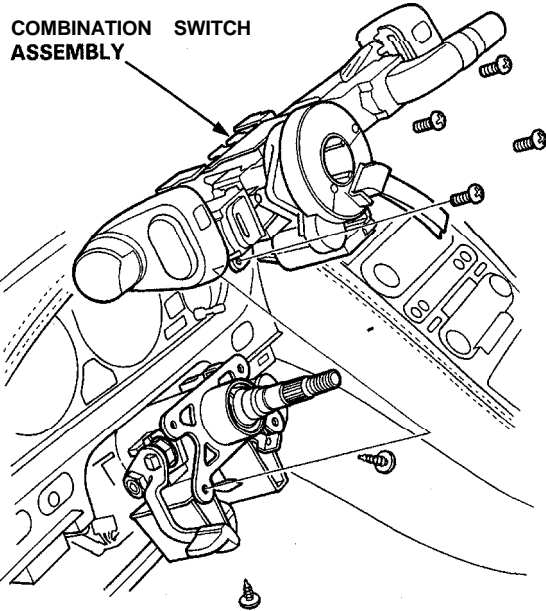

8. Remove the steering joint cover.

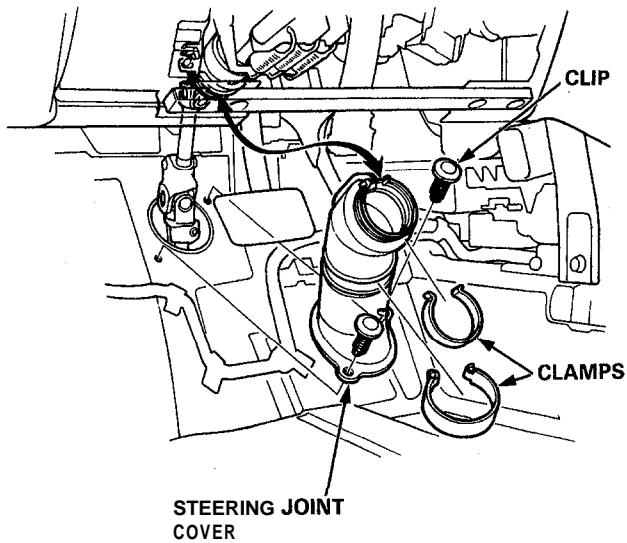

9. Remove the steering joint bolts and washers from the joints.

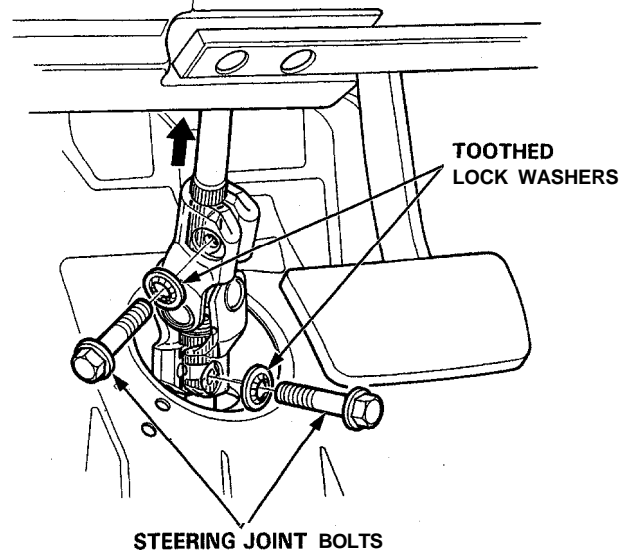

10. Disconnect the ignition switch connectors and remove the column holder, then remove the column assembly by removing the attaching nuts.

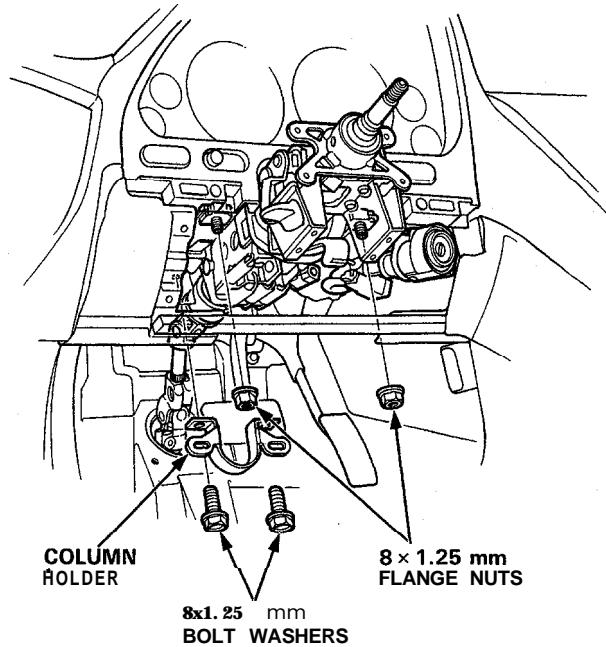

# Steering Column

## Inspection

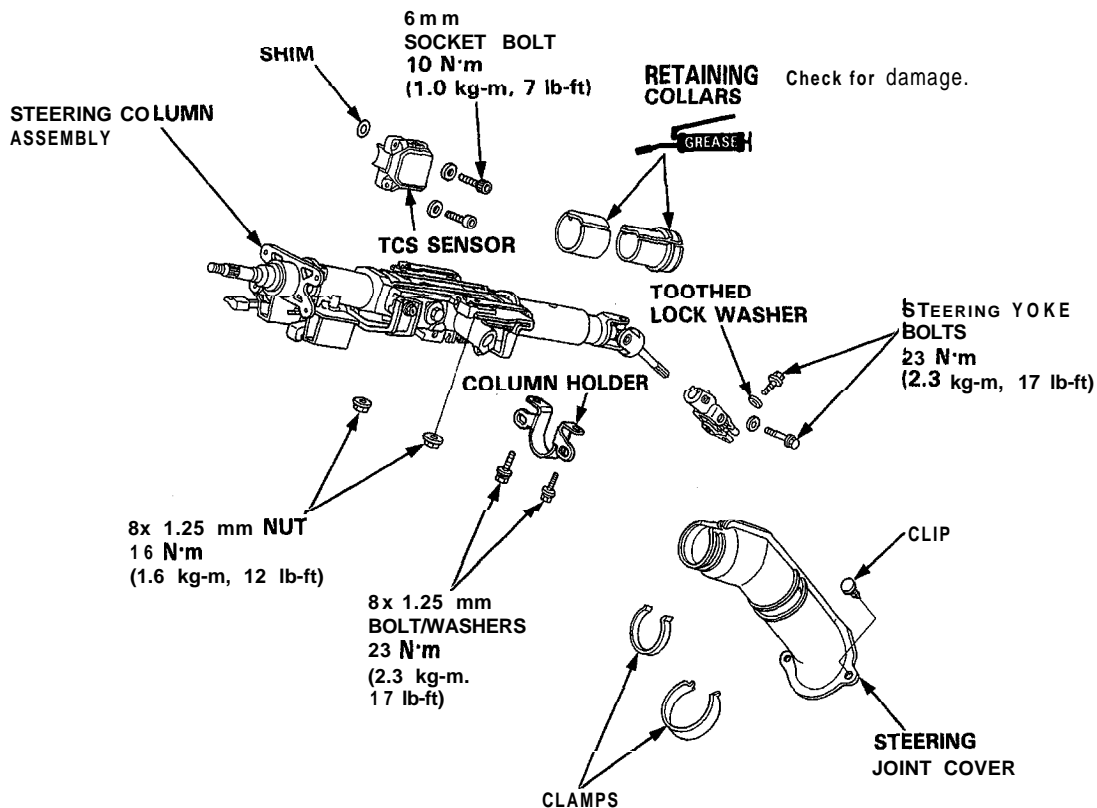

### NOTE:

- Check the telescopic mechanism, tilt mechanism, and steering joint bearings or steering shaft for movement and damage. Replace as an assembly if damaged or faulty.
- If either the steering column assembly or TCS sensor is removed, select the appropriate shim and adjust the distance between the steering shaft and TCS sensor. Refer to Section 19 for shim selection.

Attach a spring scale to the knob of the telescopic lever. Measure the force required to move the lever.

**Preload: 70-90 N (7 -9 kg, 15-20 lbs)**

If the force measured is not within the specification, loosen the locknut then the telescopic adjusting bolt until the correct force can be obtained.

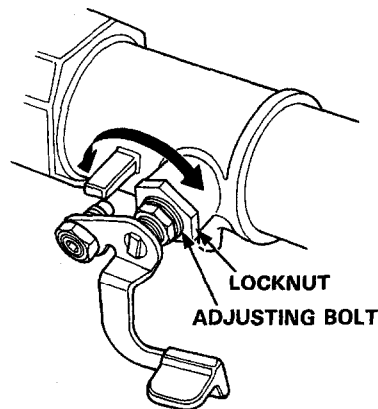
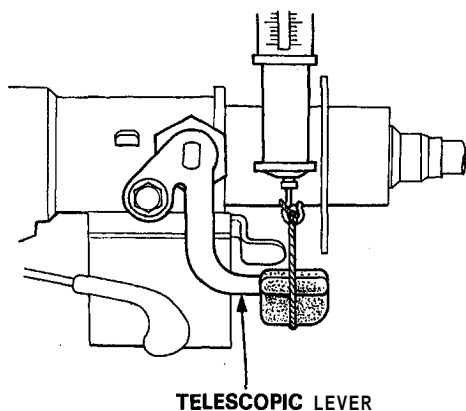



## -Installation

1. Slip the lower end of the steering joint onto the pinion shaft.
2. Reposition the column assembly on the hanger bracket and loosely tighten with 8 mm nuts.

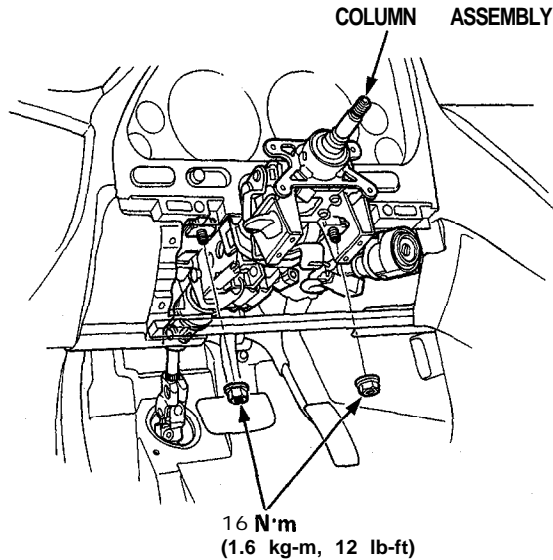

3. Tighten to the steering joint yoke bolts.

### NOTE:

- Be sure that the lower bolt is securely in the groove in the steering gearbox pinion.
- Be sure the pinion shaft and the steering column shaft are aligned; the joint should slip on freely. If not, reposition the steering rack to correct the misalignment.

### STEERING JOINT

Slip the upper end of the steering joint onto the steering shaft (line up the bolt hole with the groove around the shaft) and loosely install the upper bolt.

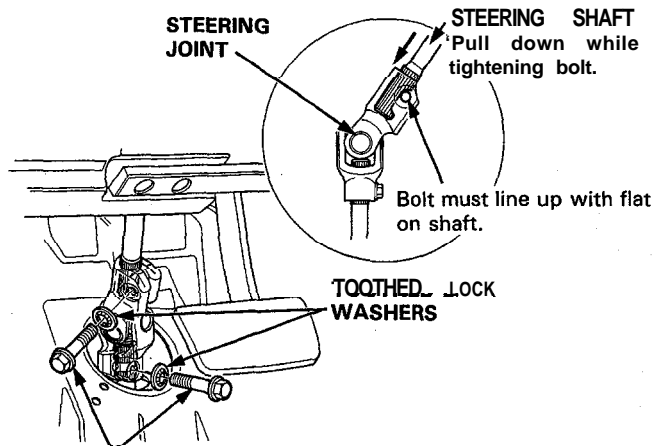

### STEERING JOINT BOLTS

23 N·m  
(2.3 kg-m, 17 lb-ft)

4. Install the column holder and bolts.

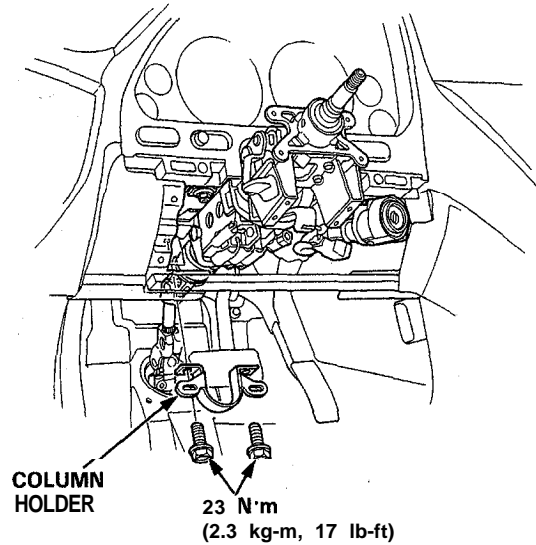

5. Tighten the 8 mm nuts to the specified torque.
6. Install the steering joint cover with the clamps and clip.

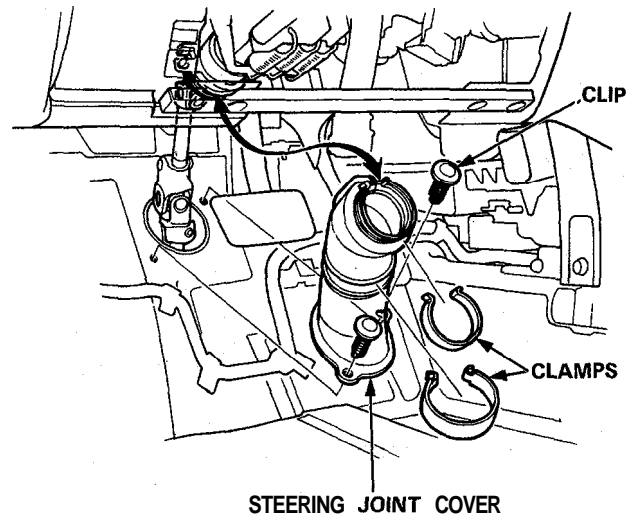

(cont'd)

# Steering Column

## - Installation (Cont'd)

7. Install the combination switch assembly on the column shaft.

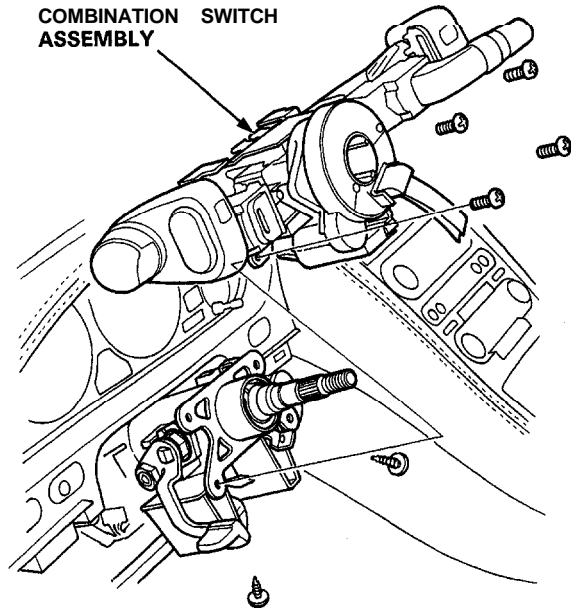

8. Reconnect TCS sensor.

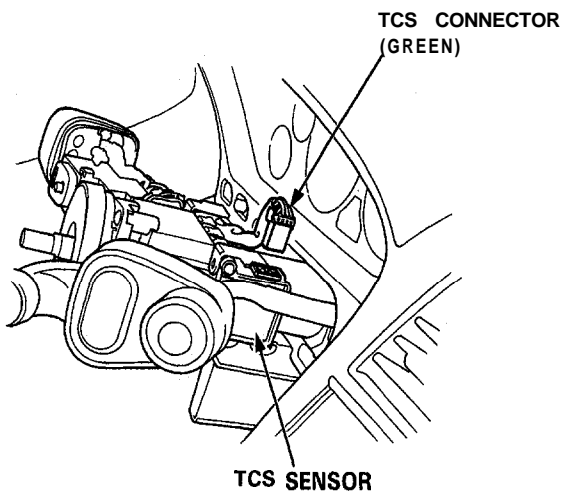

9. Install the column upper cover, and column lower cover.

NOTE: Be careful not to damage the column covers.

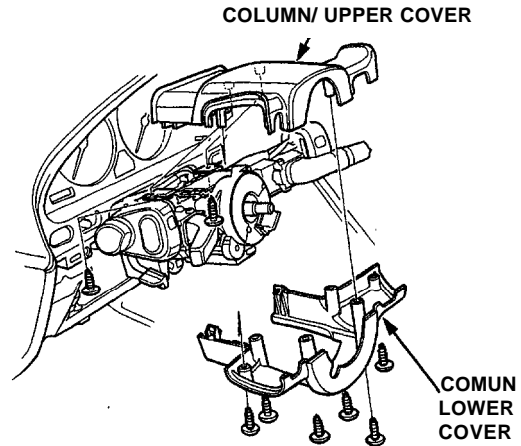

10. Connect the harness from the cable reel to the SRS main harness below the pedal bracket, then attach the connector holder to the column lower face.

11. Install the column lower face.

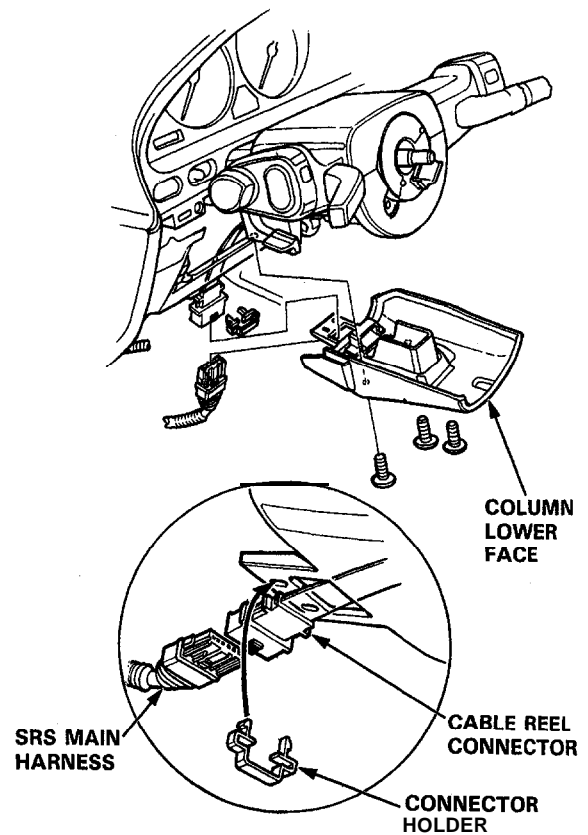





12. Install the knee bolster and pad.

13. Connect the foot light harness and light-on warning chime to the driver under cover, then install the dashboard lower panel.

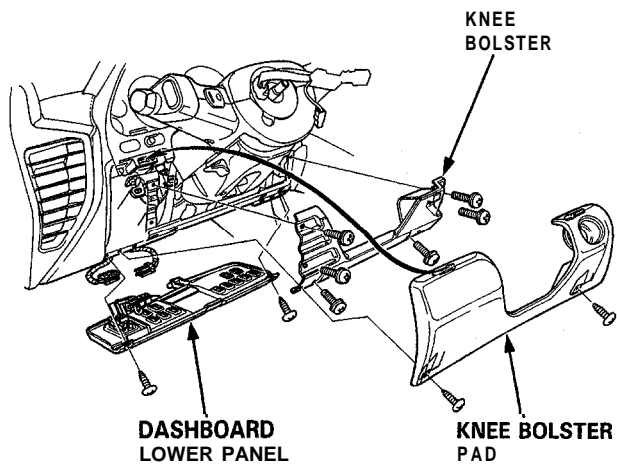

14. Install the steering wheel and SRS airbag assembly to the column. (17-10).

